

# TR Series

## Turbine Rotor Turning Rolls (Micarta-Rolls)



Turbine Rotor Turning Rolls are specialty Positioners which are very cost effective when compared to other industry alternatives such as V-blocks. Objects such as steam and gas turbines may be manipulated for sonic inspection and welding repair with the use of cranes only for mounting and unloading. Once turbines are placed upon Positioners, operators may rotate them and easily perform desired procedures. Rolls are powered with AC variable frequency drives and motors providing a large range of rotation speeds. Hand held operator pendants are standard, with optional foot switch controls available.

The Single fixed centerline setting provides a wide diameter range to accommodate many different size rotors.

The Phenolic wheels provide a hard, dense surface that will not mar the machined turbine journal like steel rollers and unlike rubber tires, Micarta will not deflect or absorb debris that can also damage the rotor journal.

Sub-base risers can be added for large diameter fins, providing swing clear-

**Oversized wheels for increased clearances, larger capacities and special engineering available!**

**Capacities from 50 to 250 Ton**



**KOIKE ARONSON, INC. / RANSOME**

P.O. Box 307, Arcade, New York 14009  
Phone (585) 492-2400 Fax (585) 457-3517  
www.koike.com

### Features

- ◆ Precision machined wheels in rigid chassis to prevent end creep
- ◆ Phenolic laminated Wheels
- ◆ Variable Frequency drives and motors
- ◆ 8" to 32" Diameter capacity
- ◆ Optional fixed height sub-bases
- ◆ Optional infinitely adjustable power elevating sub-bases



SPECIFICATIONS SUBJECT TO CHANGE

# Specifications



## Micarta Rolls (Turbine Rolls)

SPECIFICATIONS, Micarta Roll Sets	Weight Capacity (set)	Concentric Turning Capacity	Diameter Range	Speed Range (IPM)	Dim. A	Dim. B	Dim. C	Dim. D	Dim. E	Dim. F	Dim. G	Dim. H	Dim. I	Dim. J
50 PRM / 25 IRM	50 Ton (100,000 Lbs.)	50 Ton	8" - 32"	1.3-63	49"	73-5/16"	16-3/4"	3"	4-3/16"	11-3/8"	28-3/4"	7-1/2"	51-7/8"	14-1/4"
75 PRM / 35.5 IRM	75 Ton (150,000 Lbs.)	75 Ton	8" - 32"	1.3-63	49"	73-5/16"	16-3/4"	3"	6-5/16"	13-1/2"	28-3/4"	7-1/2"	51-7/8"	16-11/16"
100 PRM / 50 IRM	100 Ton (200,000 Lbs.)	100 Ton	8" - 32"	1.3-63	49"	73-5/16"	17-3/4"	3"	8-7/16"	17-1/4"	32"	6-5/8"	52-1/8"	22-1/4"
125 PRM / 62.5 IRM	125 Ton (250,000 Lbs.)	125 Ton	8" - 32"	1.3-63	49"	79-7/16"	17-3/4"	3"	10-1/2"	21-5/8"	38-7/8"	6-5/8"	52-1/8"	24-3/8"
150 PRM / 75 IRM	150 Ton (300,000 Lbs.)	150 Ton	8" - 32"	1.3-63	49"	79-7/16"	17-3/4"	3"	12-9/16"	23-5/8"	38-7/8"	6-5/8"	52-1/8"	26-3/8"
175 PRM / 87.5 IRM	175 Ton	175 Ton	8" - 32"	1.3-63	49"	80-3/4"	17-3/4"	3"	14-21/32"	25-3/4"	42-1/2"	6-5/8"	52-1/8"	28-1/2"
200 PRM / 100 IRM	200 Ton (400,000 Lbs.)	200 Ton	8" - 32"	1.3-63	49"	80-3/4"	17-3/4"	3"	16-3/4"	27-7/8"	45"	6-5/8"	52-1/8"	30-5/8"
225 PRM / 112.5 IRM	225 Ton (450,000 Lbs.)	225 Ton	8" - 32"	1.3-63	49"	80-3/4"	18-1/4"	3"	18-3/4"	27-7/8"	48"	6-5/8"	52-1/8"	33-1/4"
250 PRM / 125 IRM	250 Ton (500,000 Lbs.)	250 Ton	8" - 32"	1.3-63	49"	80-3/4"	18-1/4"	3"	20-15/16"	32"	49-7/16"	6-5/8"	52-1/8"	35-5/16"

SPECIFICATIONS SUBJECT TO CHANGE

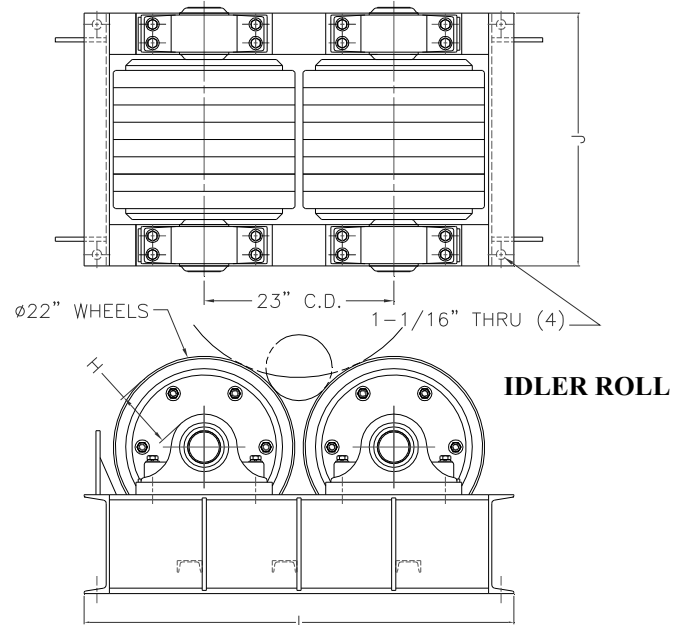
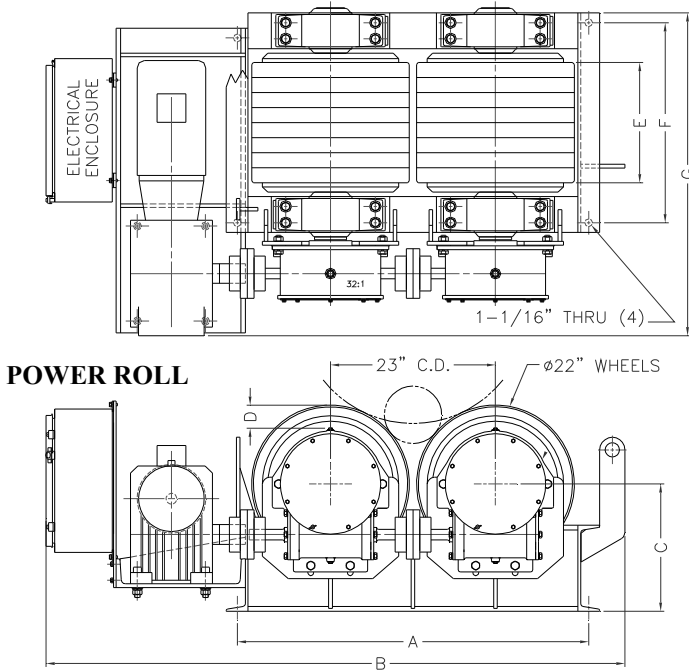

**KOIKE ARONSON, INC. / RANSOME**

Main Office:  
P.O. Box 307, Arcade, New York 14009  
Phone (585) 492-2400 Fax (585) 457-3517

Visit us at [www.koike.com](http://www.koike.com)