



WELDING &
POSITIONING

CRICKET-I

WELDING MANIPULATOR

**UNPRECEDENTED
VALUE FOR ALL
SHOP SIZES.**



The latest cost-efficient, American-made welding manipulator

Ruggedly built, the Cricket-I provides the same reliability and robust performance found with all Koike machines, offering fabricators a variety of premium features with a small enough footprint to fit into any size shop. The Cricket-I provides a stable and repeatable platform for semi-automatic welding processes and is built with a 150 pound capacity with options.

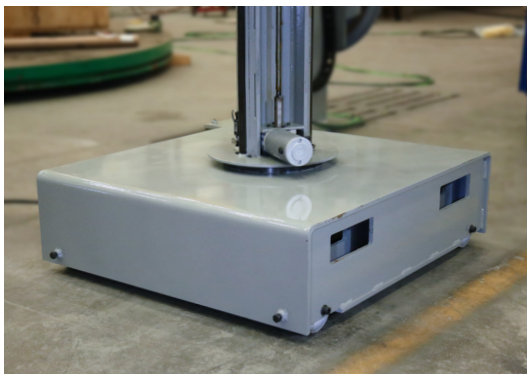

Manual Travel Car

Includes fork-truck pockets and V-wheels to run on floor or track section.

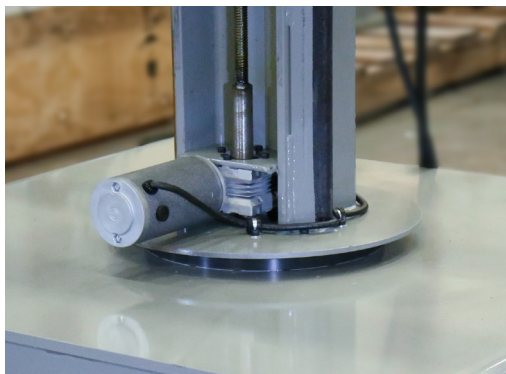

Manual Mast Rotation

A graduated bevel collar ensures accurate bevel setting.



Powered Vertical Lift

Ball screw driven lift for smooth operation, 20 IPM constant speed lift with pendant included.

SIMPLY BETTER BUILT.



| SPECIFICATIONS | |
|--|-------------------|
| Reach Travel | Manual |
| Dim A: Standard Reach Travel | 72 in |
| Dim B: Min. reach distance from CL of Mast | 10 in |
| Dim C: Max. reach distance from CL of Mast | 82 in |
| Dim D: Height overall (HOA) without track | 109-1/2 in |
| Lift Speed | 20 lpm |
| Lift Motor HP | 1/8 hp |
| Dim E: Min. lift from floor to CL of boom | 22-3/4 in |
| Dim F: Max. lift from floor to CL of boom | 94-3/4 in |
| Weight Capacity (either end or split) | 150 pounds |
| Boom end plate | 6 in x 6 in |
| Car Dimensions | 40-1/4 in x 37 in |
| Rail gauge (Dual V) | 32-1/2 in |
| Machine Voltage | 115/1/60 @ 20 AMP |

*Specifications are subject to change without notice

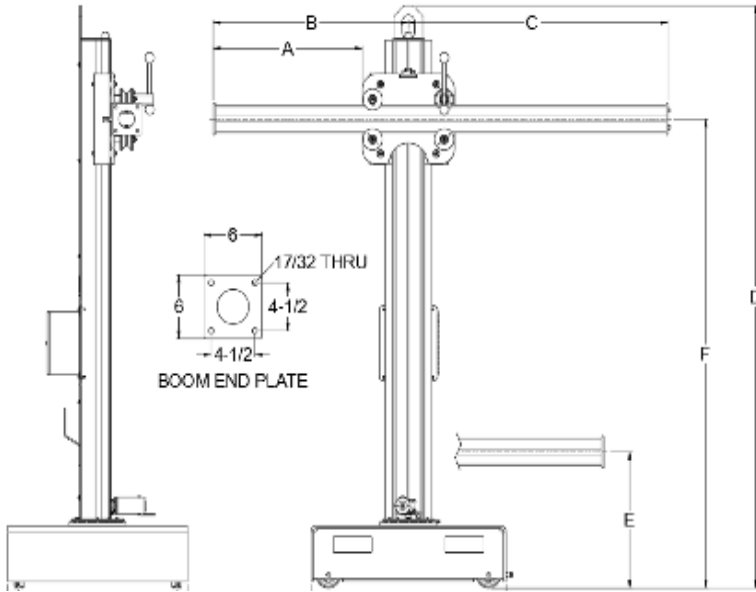

Cricket-I OPTIONAL EQUIPMENT

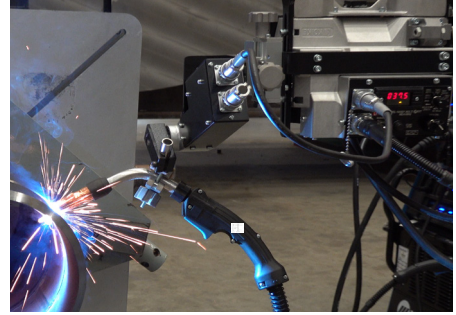

Pipe Welding Package

Includes Wel-Handy Next

Programmable WU-3 Weaver and control

3 in x 3 in manual cross slide

Mounting brackets for pendants and welding controls

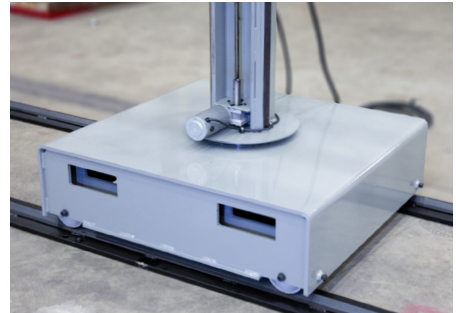

Rail Sections

32-1/2 in low profile rail gauge

Dual V, inverted angle iron

Available in 10 ft lengths



Simply better built – for over 100 years. Our strictly controlled manufacturing and production processes ensure we have the highest-quality machines with the most reliable performance. We collaborate with our customers to produce the right machine for their needs within a range of budgets.

Visit Koike.com/home for more information or contact your local distributor.



WELDING &
POSITIONING



CUTTING



PORTABLES &
GAS APPARATUS

Learn More



WWW.KOIKE.COM



635 W Main St.
Arcade, NY 14009
Ph: 585-492-2400