



WELDING &
POSITIONING

MD-HTS-PE

POWER ELEVATING HEAD AND TAILSTOCK



SIMPLY BETTER BUILT.





Compact High Capacity Head & Tailstocks

The MD series Power Elevating Head and Tailstock is designed with premium features in a package compact enough to fit in small shops, but also ruggedly built. The MD Head and Tailstocks have the same reliability found with all Aronson Positioners.



Both Axis electrically driven.

Variable speed rotation and constant speed elevation standard, controlled with AC Variable frequency drives. Elevation axis on the base model utilizes an open loop VFD drive system with internal PLC monitoring faults and over-travel limits. System maintains alignment with even loading within +/- 0.580" per 1,000 inches of travel or 700 start/stop cycles. Optional closed loop system is available for tighter control.

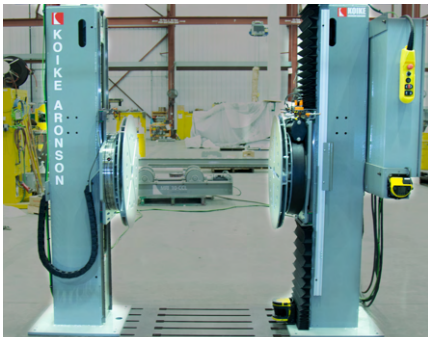

Compact Design

Single post design allows for better shop floor utilization.

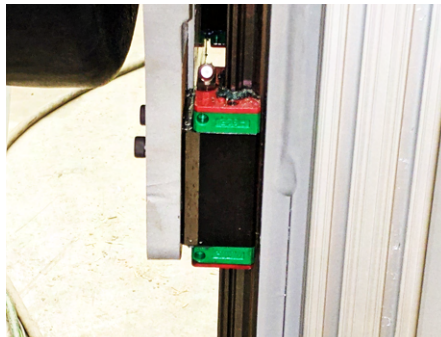

Linear way Guidance

High capacity precision guidance throughout the entire elevation range.

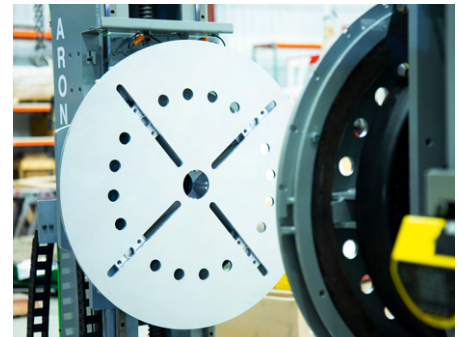
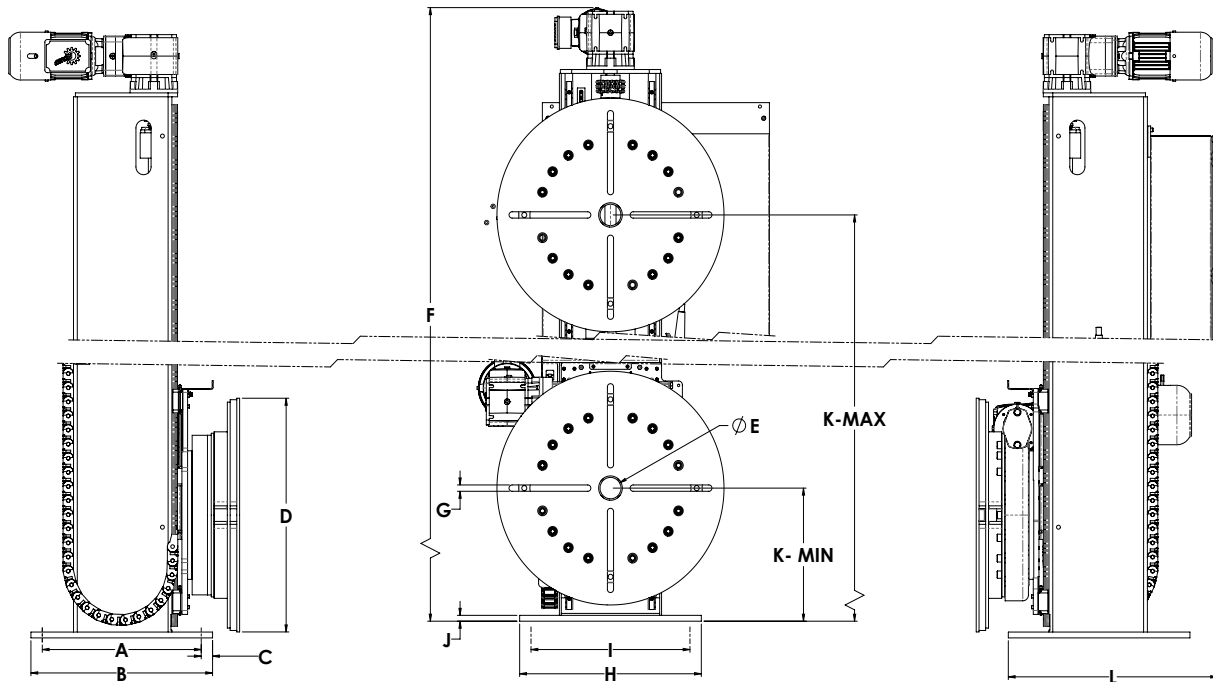

Table Included

Fabricated table with mounting slots and 500 Amp sliding weld ground shoe.

Model	MD-HTS-5PE	MD-HTS-10PE	MD-HTS-15PE	MD-HTS-20PE
Load Capacity, lb (Max. Between Head & Tailstock)				
6"	5,000 lb	10,000 lb	15,000 lb	20,000 lb
12"	2,500 lb	5,000 lb	7,500 lb	10,000 lb
18"	1,667 lb	3,333 lb	5,000 lb	6,667 lb
24"	1,250 lb	2,500 lb	3,750 lb	5,000 lb
30"	1,000 lb	2,000 lb	3,000 lb	4,000 lb
Rotation: Torque, in-lb	30,000	60,000	90,000	120,000
Rotation Speed, rpm	.1-1	.1-1	.1-1	.1-1
Pendant Cable Length	20'	20'	20'	20'
Ground Cable (amps)	500	500	500	500
A: Dimension	21"	21"	27"	27"
B: Dimension	24"	24"	30"	30"
C: Dimension	1.5"	1.5"	1.5"	1.5"
D: Table Size	30"	30"	48"	48"
E: Through Hole	2.75"	2.75"	5"	5"
F: Dimension	91(1/2)"	91(1/2)"	106"	106"
G: Number of Slots and Width	4 (13/16)"	4 (13/16)"	4 (1-1/8)"	4 (1-1/8)"
H: Dimension	24"	24"	30"	30"
I: Dimension	21"	21"	27"	27"
J: Dimension	21"	21"	27"	27"
K: CL Height Range (Elevation 30 IPM)	15.5"-63.5"	15.5"-63.5"	27"-75"	27"-75"
L: Dimension	27(1/2)"	27(1/2)"	36"	36"
Approximate Weight (Headstock) lb	1800 lb	1800 lb	2600 lb	2600 lb
Approximate Weight (Tailstock) lb	1260 lb	1260 lb	2000 lb	2000 lb
Standard Voltage	480/3/60	480/3/60	480/3/60	480/3/60



MDHTS-PE OPTIONAL EQUIPMENT



Tailstock Mobile Sub-base

Provides easy table to table adjustment for varying length parts.

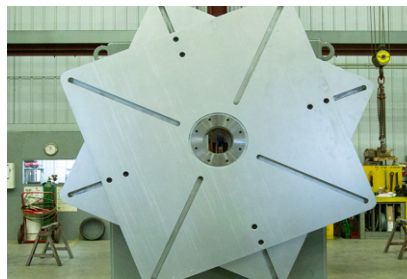

Flex Plate Fixturing Table

Offers flexible machine connection to protect against misalignment and thermal expansion alignment issues.

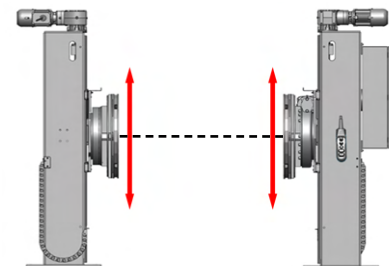

Synchronized Elevation Axis

Closed loop encoded lift axis provides synchronization of +/- 0.05" per 1,000 inches of travel.

Be the standard. Raise the standard.

All of our machines are manufactured inside of our walls ensuring we deliver our customers the highest-quality machines with the longest lasting performance on the market. All Koike machines are designed and developed in the United States, allowing for accessible service, parts and support.



Simply better built – for over 100 years

Our strictly controlled manufacturing and production processes ensure we have the highest-quality machines with the most reliable performance. We collaborate with our customers to produce the right machine for their needs within a range of budgets.

Koike products help our customers:

- ✦ Improve productivity
- ✦ Create greater efficiency
- ✦ Save labor with easy operation
- ✦ Produce consistent, high-quality outputs
- ✦ Reduce costs
- ✦ Increase workplace safety



WELDING & POSITIONING

- Positioners
- Turning Rolls
- Head & Tailstocks
- Manipulators
- Tank Fabrication
- Welding Packages

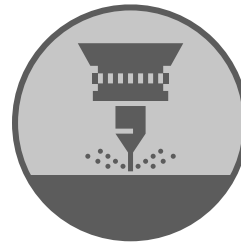

CUTTING

- Plasma
- Oxy-fuel
- Waterjet
- Plate Laser



PORTABLES & GAS APPARATUS

- Portable CNC Cutting
- Mechanized Pipe/Plate Cutting
- Portable Welding Carriages
- Bench Top Positioners
- Gas Apparatus & Hand Torches

Visit [Koike.com/home](https://www.koike.com/home) for more information or contact your local distributor.

635 West Main St., Arcade, New York, USA 14009
Toll-Free: 800.252.5232 U.S. & Canada: 585.492.2400
[Koike.com/home](https://www.koike.com/home)



Learn more

