



CUTTING

ShopProTM

CNC PLASMA & OXY-FUEL CUTTING MACHINE



SIMPLY BETTER BUILT.



FEATURES AT A GLANCE:

**1. EMERGENCY STOP BUTTON**

An E-stop button is located on each saddle to quickly and safely shut off machine motion and cutting process, including oxy-fuel gases to the torches.

2. WATER TABLE

Equipped with curved slats, this table facilitates loading of materials by allowing plates to be placed and slid into position with ease. This is particularly suitable for environments lacking overhead crane accessibility, minimizing the need for excessive floor space.

3. ALL-IN-ONE MOTION CONTROLLER

Fit with a 21" touch screen.

4. STEEL-MADE BEAM AND SADDLES

Fabricated steel gantry designed for heavy-duty cutting needs, allowing for wider cutting widths and shorter cutting lengths.

5. MAGNETIC TORCH BREAKAWAY

Equipped to protect against torch collision.

6. DESIGNATED FORKLIFT INSERTS

Housed right into its fully welded frame, the heavy-duty ShopPro™ was designed with easy installation and relocation in mind.

UNRIVALED VALUE FOR SMALL SHOPS

The KOIKE ShopPro™ is the company's newest cost-effective, made in America, high performance cutting system, offering premium features in a package compact enough to fit in small shops. Developed with the help of feedback of fabricators and metal workers, who demanded a robust feature set at an economical price-point, the ShopPro™ was ruggedly built to showcase the same reliability and accuracy found with all KOIKE cutting systems.

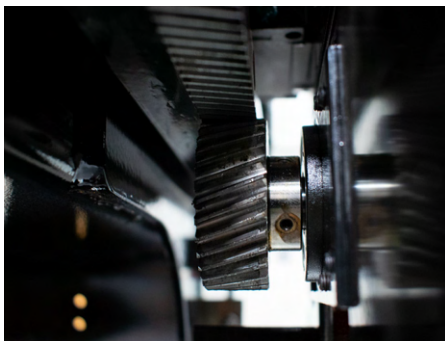
**Dual Side Drive with Helical Gear Rack with AGMA 12 Grade Ground Pinions:**

Provides smooth and accurate motion.

**Precision Ground Linear Guideways With Preloaded Linear Bearings:**

Designed for tighter tolerance, longer service life and high output.

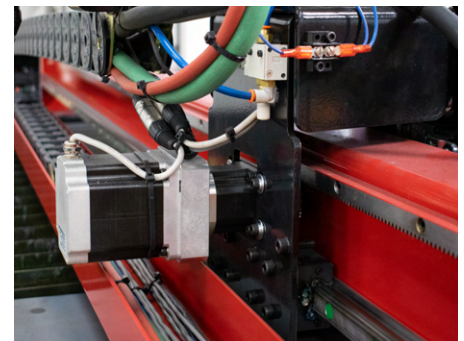
**Precision Helical Gearboxes:**

With NEMA-34 Stepper motors.

SIMPLY BETTER BUILT.

ALL-IN-ONE MOTION CONTROLLER WITH 21" TOUCH SCREEN



FEATURES AND BENEFITS

- **PRO Version Software Package**
- On-Board Completely Integrated FlashCut 2D CAM/CAD Package
- True Shape Nesting
- Customizable Cut Charts
- Customizable Default Lead-In, Lead-Out Strategies
- Silhouette Image Import
- Tapping of Part
- DXF/DWG Import
- Overburn Support
- Marker and Plasma Marking
- DXF Export
- Advanced Text Including True Type Font Support Without Exploding and Curved Text Around Any Shape
- Part Shading
- 3D Cutting Simulation
- Automatic Lead-In on Restart
- Dynamic THC On/Off
- Progress Meter
- Move to Point in Viewport
- Rip Cutting
- Smart Touch Off
- Shape Library
- Bridge Entities Tool
- Shape Welding Tool
- Multi-Layer Color Image Import
- Import of Parts From External Files
- Multi-Sheet and Fill Sheet Trueshape Nesting
- Corner looping
- Advanced Lead-In, Lead-Out Editing
- Animated 3D Cutting Simulation
- Advanced Small Hole Processing

YOUR CHOICE BETWEEN THREE TABLE SIZES

Meet your personal production and space requirements with three sizing options.



CONVENTIONAL PLASMA SYSTEMS OFFERED FOR THE SHOPPRO™

The next generation of Powermax65®/85/105 systems is unlike any plasma you've seen before. Featuring built-in intelligence and a revolutionary single-piece cartridge consumable, Powermax SYNC™ series helps to address skilled labor shortages with its simplified system operation. This new platform streamlines consumable inventory, lowers operating costs, and maximizes performance and productivity.



Hypertherm® Powermax45XP

Hypertherm® Powermax85 SYNC®

Hypertherm® Powermax125

Hypertherm® Powermax65 SYNC®

Hypertherm® Powermax105 SYNC®

SIMPLY BETTER BUILT.



▪ Oxy-Fuel Torch

Koike cutting tips are one of the most technically advanced of its kind. By the simple swapping out of the plasma torch, the oxy-fuel torch extends the ShopPro's cutting capability up to 2 in. (50mm). The oxyfuel torch can be parked on the backside of the torch carriage when not in use. Features a lifetime warranty when using genuine KOIKE cutting tips.

▪ Pneumatic Scribe Assembly

A manually swappable engraving tool for marking text, layout lines, bend lines and drilling locations. Scribe process parameters are pre loaded in the CNC controller software. Patent pending Ohmic Contact System prompts Initial Height Sensing (IHS) and detects the plate automatically to set the tool to precise marking depths. Features manual on/off.

▪ Downdraft Plenum Table

Features a bolt on design fume extraction hood, mounted to the backside of the cutting table. This option allows extra removal of fume during plasma cutting. It includes one or two, 12 in. diameter cut outs for the supplied fume collector.

(Not available for oxy-fuel cutting option.)

▪ Water Additive

Prevents bacterial growth in water table. Also features a rust inhibitor to minimize rust in the table, slats and on plate surfaces and parts. Contact KOIKE for details.

▪ Roll-A-Round CNC Cabinet

Protects your controller from the harsh cutting environment and moves easily on 4 industrial casters (2 with brakes).



Oxy-fuel torch option

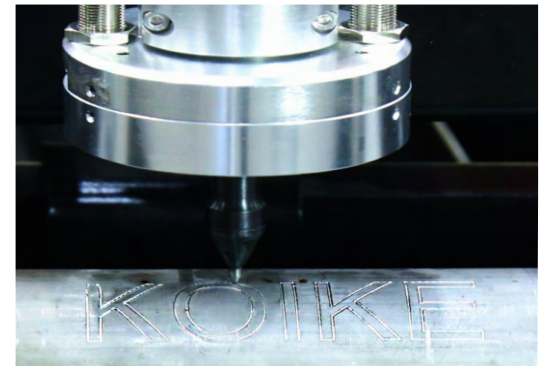

Pneumatic scribe option



Downdraft plenum table

SIMPLY BETTER BUILT.



Get more use out of your ShopPro™

ShopPipe™ incorporates easy to use software, easy setup and low maintenance mechanicals that are built to withstand the harsh work environment. A fold-down head design saves space and makes it easy for existing customers to upgrade. The direct drive system with chuck precisely rotates the pipe, unlike competitors that use friction drive system with rollers or belts. The work cell is kept cleaner with built-in cutting slag pans and using a through-hole chuck design to safely and effectively remove smoke.

SPECIFICATIONS	
Maximum Pipe Diameter	6 in. (152 mm) with 1/2 in. (12.7 mm) wall
Maximum Pipe Length	8 ft. (2.44 m)
Number of Supports in Base Model	3
Maximum Weight Capacity	150 lbs. per support (max total weight 600lbs.)
Drive Means	Direct drive with chuck
Fume Collector Connection Point	Yes
Spark and Slag Pan	Yes
Spark Arrestor	Yes

*Specifications are subject to change without notice



EASY TO SETUP AND ADJUST PIPE FOR CUTTING



SPACE SAVING FOLD DOWN TOOL HEAD (PATENT PENDING)



REMOVABLE SLAG PANS FOR EASY CLEAN UP



THROUGH-HOLE CHUCK DESIGN WITH BUILT-IN SPARK ARRESTOR

SIMPLY BETTER BUILT.



Specifications

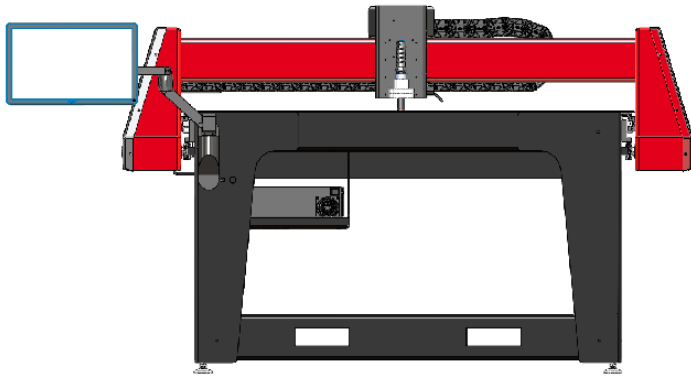

Front View
4'x4' model

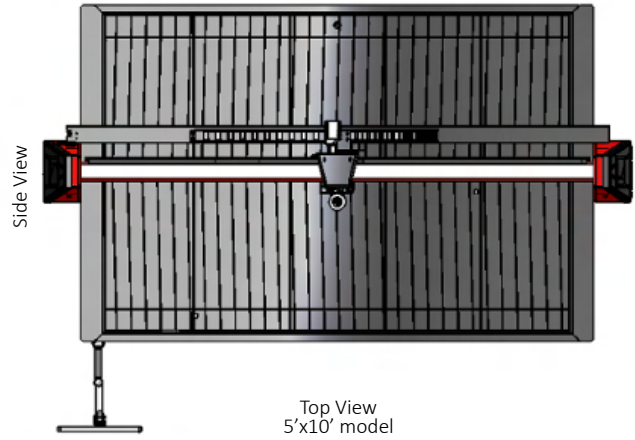

Top View
5'x10' model

ShopPro™	SP-44	SP-48	SP-510
Effective Cutting Area	4 ft. x 4 ft.	4 ft. x 8 ft.	5 ft. x 10 ft.
Effective Cutting Width	48 in.	96 in.	120 in.
Effective Cutting Length	48 in.	48 in.	60 in.
Rapid Traverse Speed	1000 IPM	1000 IPM	1000 IPM
Machine Width	78 in.	126 in.	150 in.
Machine Length (CNC not included)	72 in.	72 in.	84 in.
Table Dimensions	78 in. x 72 in. x 56 in.	126 in. x 72 in. x 56 in.	150 in. x 72 in. x 56 in.
Machine Weight	1300 lbs.	2200 lbs.	3500 lbs.
Tool Capacity	2	2	2
Water Capacity	65 gallons	148 gallons	220 gallons
Table Capacity	2 inch Mild Steel		
Machine Voltage	115/1/60 @ 15 amp		
CNC Controller	FlashCut CNC 21" Touchscreen Panel PC		
Drive System	Stepper		
Table Type	Water Pan Insert		
Rack and Pinion Drive System			
Gear Reduction	(3) Precision Helical 15:1 gearboxes		
Linear Guidance	25mm Profile Linear Rail, 30mm Gantry		
Gear Engagement	Direct Drive Helical Rack and Pinion		
Gantry Carriage	Solid Steel Construction		
Machine Repeatability	0.0015"		
Frame Construction	7 Gauge Mild Steel		

*Specifications are subject to change without notice



Simply better built – for over 100 years. Our strictly controlled manufacturing and production processes ensure we have the highest-quality machines with the most reliable performance. We collaborate with our customers to produce the right machine for their needs within a range of budgets.

Visit Koike.com/home for more information or contact your local distributor.



WELDING &
POSITIONING



CUTTING



PORTABLES &
GAS APPARATUS



Learn More



WWW.KOIKE.COM



635 W Main St.
Arcade, NY 14009
Ph: 585-492-2400