

# Assembly drawing

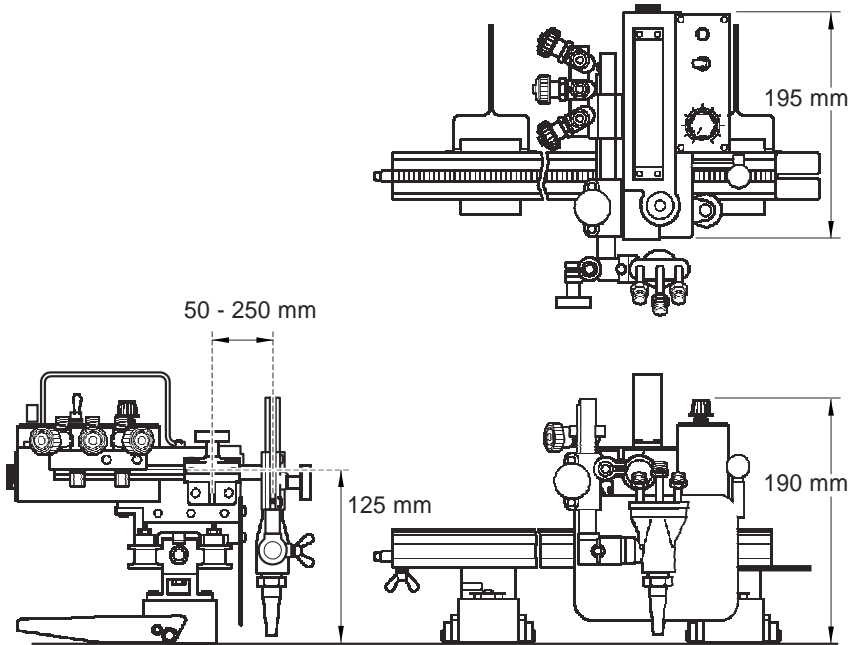
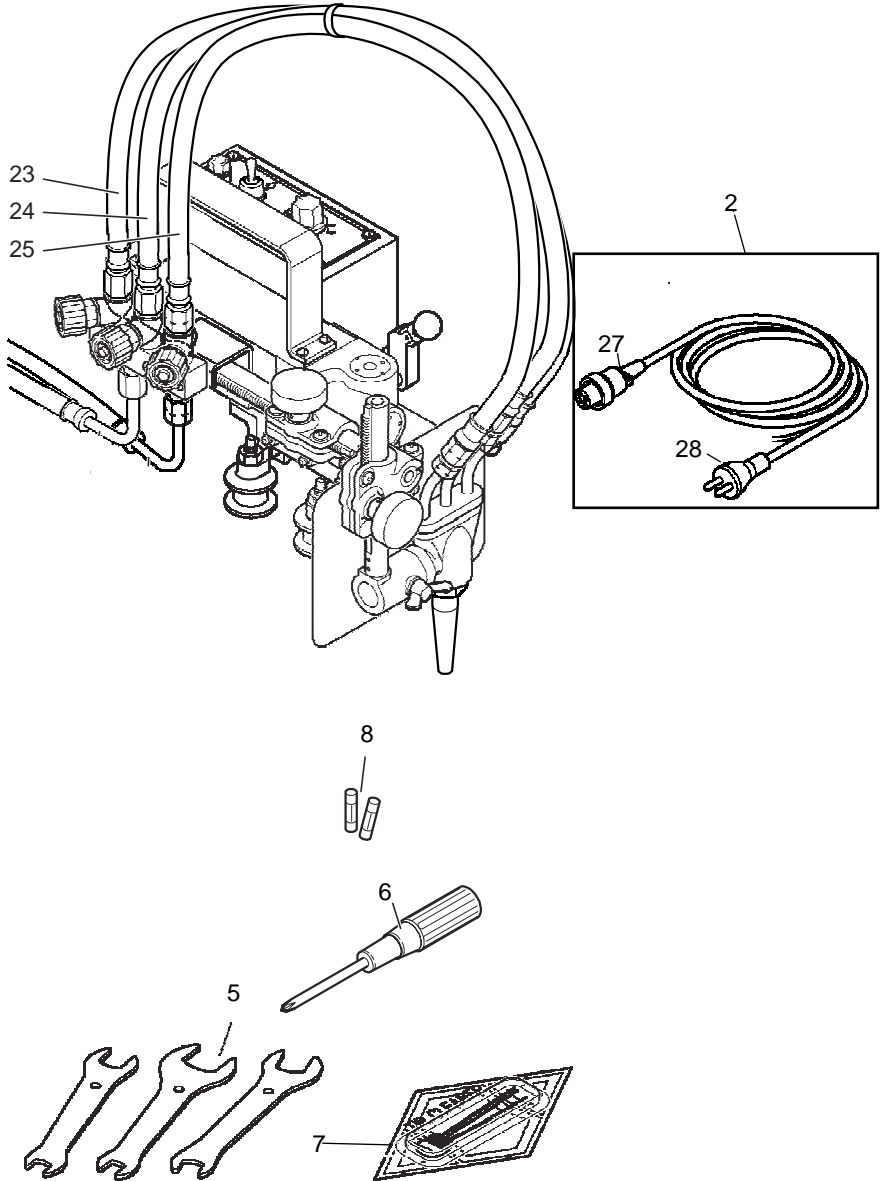

figure 8 - 2

## 9 Parts list

### 9.1 Complete IK-72T set



<b>ITEM NUMBER</b>	<b>PART DESCRIPTION</b>	<b>QUANTITIY</b>	<b>PART NUMBER</b>	<b>REMARKS</b>
2	CABTYRE CORD ASSEMBLY	1	61004264	
5	SPANNER	1	ZS30309	
6	SCREW DRIVER	1	ZS30310	
7	TIP CLEANER	1	ZS30311	
8	FUSE	1	9938728000	
23	JET OXYGEN HOSE	1	ZM30303	
24	PREHEAT OXYGEN HOSE	1	ZM30303	
25	GAS HOSE	1	ZM30307	
27	METAL PLUG	1	ZS30275	3P
28	PLUG	1	ZS31295	

## 9.2 Main unit 1

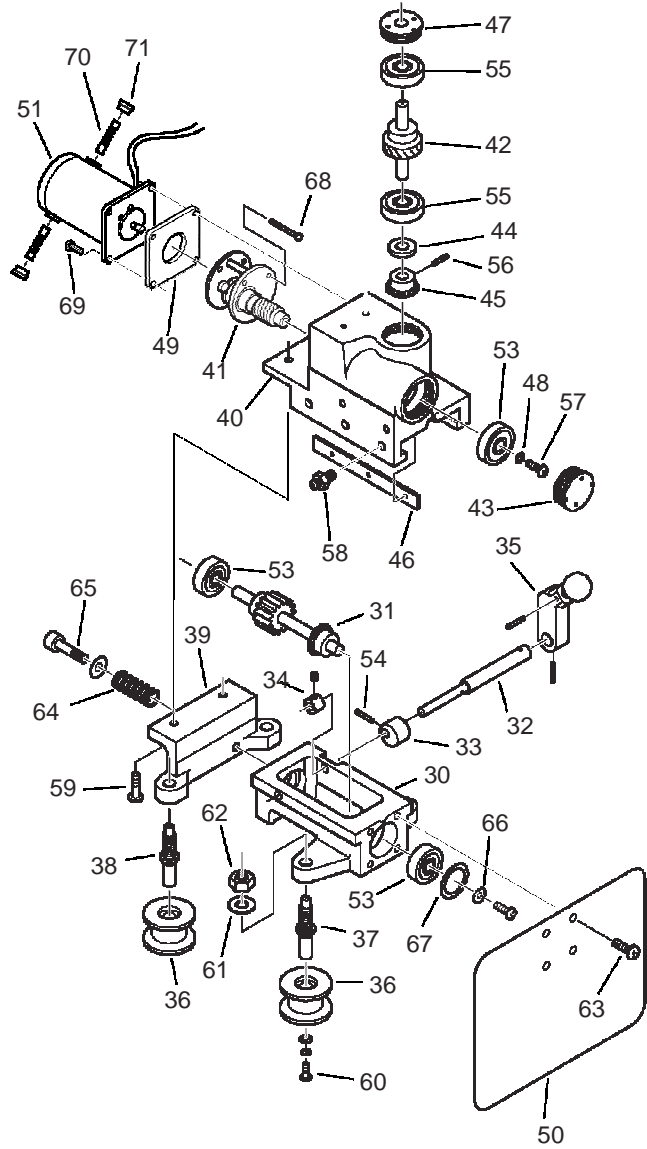

ITEM NUMBER	PART DESCRIPTION	QUANTITY	PART NUMBER	REMARKS
30	MACHINE BASE	1	ZS31674	
31	DRIVE SHAFT ASSEMBLY	1	ZS31606	
32	CLUTCH SHAFT	1	ZS31607	
33	ECCENTRIC ROLLER	1	ZS31608	
34	STOPPER	1	ZS31609	With Screw
35	CLUTCH HOLDER ASSEMBLY	1	ZS31610	
36	SIDE ROLLER ASSEMBLY	4	ZS31611	
37	SIDE ROLLER SHAFT (A)	2	ZS31612	
38	SIDE ROLLER SHAFT (B)	2	ZS31613	ECCENTRIC
39	SIDE ROLLER BRACKET	1	ZS31675	
40	GEAR BOX	1	ZS31615	
41	GEAR ASSEMBLY	1	61000715	
42	WORM WHEEL ASSEMBLY	1	ZS31617	
43	BEARING RETAINER	1	ZS31618	
44	COLLAR (A)	1	ZS31619	
45	BEVEL GEAR (B)	1	ZS31620	
46	SLIDE KEY	1	ZS31621	
47	BEARING RETAINER	1	ZS31618	
48	WASHER	1	ZS31015	
49	MOUNTING PLATE	1	61000546	
50	HEAT SHIELD	1	ZS31629	
51	MOTOR	1	61001062	24V,15W,5000RPM
53	BEARING	3	1138352600	627ZZ

ITEM NUMBER	PART DESCRIPTION	QUANTITY	PART NUMBER	REMARKS
54	SPRING PIN	1	9968202000	PR-2X12
55	BEARING	2	1138358800	628ZZ
56	ROLL PIN	1	9968204300	PR-2.5X16
57	SCREW	1	9968174500	SP-4X4
58	SET SCREW	3	9968273500	SS-5X5
59	SCREW	2	9968177400	SP-5X14 w/washer
60	SCREW	4	9968172600	SP-3x6 w/washer
61	WASHER	4	9968148800	WF-6
62	HEX NUT	4	9968123300	NH-6
63	SCREW	8	9968174800	SP-4x8
64	SPRING	1	ZS31676	
65	HEX. SOCKET HEAD SCREW	1	9968129000	BC-5X30
66	WASHER	1	9968148700	WF-5
67	LINER	1	ZS31684	
68	SCREW	3	9968185100	SP-2X25
69	SCREW	4	9968175400	SP-4X18
70	CARBON BRUSH	2	ZS31693	
71	CARBON CAP	2	ZS33545	

## 9.3 Main unit 2

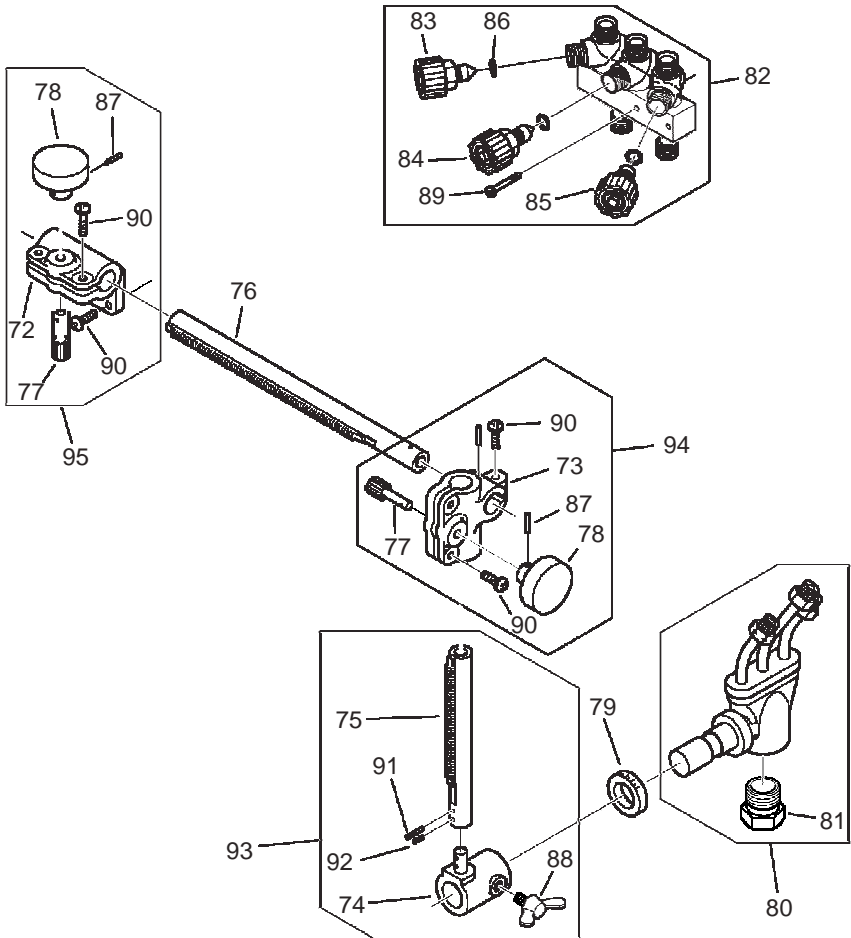

ITEM NUMBER	PART DESCRIPTION	QUANTITY	PART NUMBER	REMARKS
72	CROSS FEED BASE	1	ZS31623	
73	VERTICAL SLIDE BASE	1	ZS31665	
74	TORCH HOLDER BASE	1	ZS31624	
75	VERTICAL BAR	1	ZS31625	WITH RACK
76	CROSS FEED BAR	1	ZS31626	WITH RACK
77	PINION	2	ZS31627	
78	HANDLE	2	ZS31628	
79	GRADUATION COLLAR	1	ZS30906	
80	TORCH	1	ZS10302	
81	TIP FIXING NUT	1	ZS05020	
82	DISTRIBUTOR	1	ZS31631	
83	JET OXYGEN VALVE	1	ZS15351	
84	PREHEAT OXYGEN VALVE	1	ZS15355	
85	GAS VALVE	1	ZS15356	
86	O-RING	3	ZS05026	
87	SPRING PIN	2	9968202000	PR-2X12
88	WING BOLT	1	9968231100	BS-5X10
89	SCREW	2	9968175500	SP-4X20
90	SCREW	7	9968177600	SP-5X16
91	SPRING PIN	1	9968202100	PR-2X13
92	SPRING PIN	1	9968201700	PR-2X6
93	TORCH HOLDER ASSEMBLY	1	ZK31641	



<b>ITEM NUMBER</b>	<b>PART DESCRIPTION</b>	<b>QUANTITY</b>	<b>PART NUMBER</b>	<b>REMARKS</b>
<b>94</b>	<b>VERTICAL SLIDE HOLDER ASSEMBLY</b>	<b>1</b>	<b>ZS32789</b>	
<b>95</b>	<b>CROSS FEED HOLDER ASSEMBLY</b>	<b>1</b>	<b>ZS31632</b>	

## 9.4 Operation box assembly

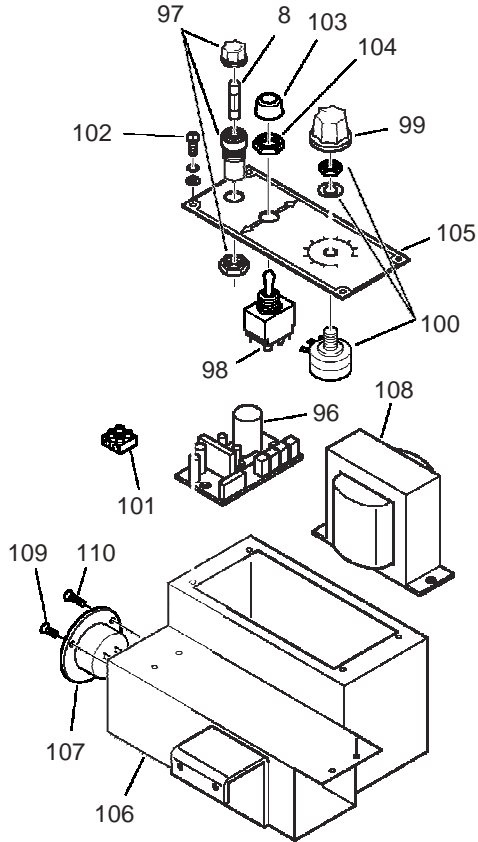

ITEM NUMBER	PART DESCRIPTION	QUANTITY	PART NUMBER	REMARKS
96	CONTROLLER	1	69000130	
97	FUSE HOLDER	1	ZS30749	
98	SWITCH	1	ZS30283	
99	HANDLE	1	ZS31249	
100	VARIABLE RESISTOR	1	6N310008	50 KW
101	TERMINAL	1	ZS31666	2P
102	SCREW	4	9968172300	SP-3X6
103	CAP FOR DUST PROTECTOR	1	ZS32431	
104	DUST PROTECTOR	1	ZS32480	
105	OPERATION PANEL	1	61000566	
106	OPERATION BOX	1	61000588	
107	METAL SOCKET (3P)	1	ZS30273	42/100/120V
	METAL SOCKET (4P)	1	ZS30274	100/120/220V
108	TRANSFORMER	1	61000473	42V
		1	61000472	100/120/220V
		1	61000672	230/240V
109	SCREW	2	9968160900	SM-3X5
110	SCREW	1	9968172400	SP-3X8

## 9.5 Rail unit (straight rail and 2,3 dimension rail)

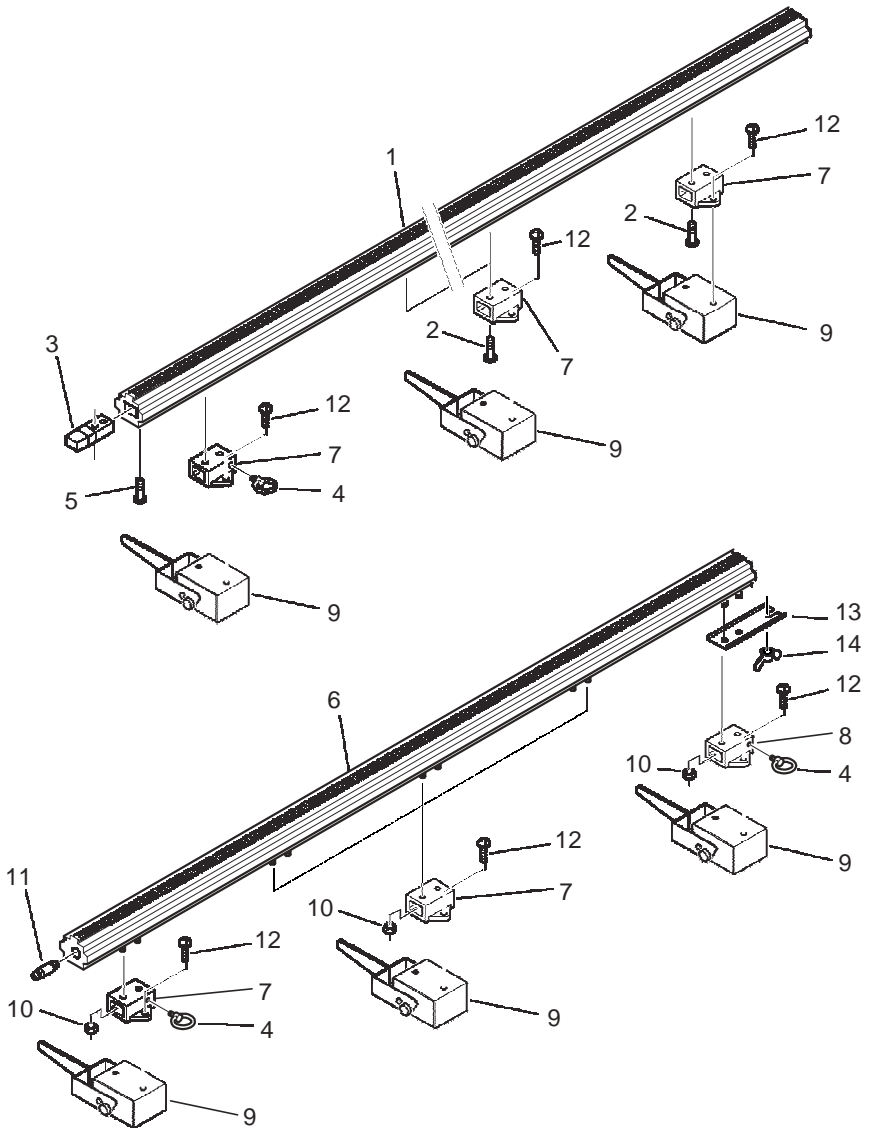

<b>ITEM NUMBER</b>	<b>PART DESCRIPTION</b>	<b>QUANTITY</b>	<b>PART NUMBER</b>	<b>REMARKS</b>
1	STRAIGHT RAIL	1	ZS31648	RAIL ONLY
2	SCREW	8	9968177400	SP-5X14
3	CONNECTOR	1	60031694	
4	HOOK BOLT	2	ZS31654	
5	SCREW	2	9968180100	SP-6x18
6	2-D RAIL	1	ZS31655	
	3-D RAIL	1	ZS31656	
7	MAGNET HOLDER(A)	4	ZS31657	
8	MAGNET HOLDER (B)	1	ZS31658	2D,3D ONLY
9	MAGNET	4	ZS31682	
10	HEX NUT	10	9968123200	NH-5
11	COUPLING PIN	1	ZS31695	2D,3D ONLY
12	SCREW	10	9968177400	SP-5X14
13	COUPLING BOARD	1	ZS31659	2D,3D ONLY
14	WING NUT	1	9968240400	NB-6